



# Visiting Instruments at the 4.2m WHT

S. A. Rix and C. R. Benn (ING)



## Introduction

The 4.2-m William Herschel Telescope on La Palma is a popular platform for innovative visiting instruments. Some are geared towards specific science programmes, while others extend the explorable 'photon parameter space' beyond that covered by the WHT's common-user instruments (e.g. by providing high time resolution or high polarisation sensitivity). On average, the WHT hosts six visiting instruments each semester. We describe some of these below and highlight the attractions of bringing new visitor instruments to the WHT.

## SAURON

During the late 1990's, attempts to study the large-scale kinematics of galaxies were hindered by the limitations of long slit spectroscopy. Collaborators from the Observatoire de Lyon, Leiden Observatory and the University of Durham addressed this problem by building SAURON, an innovative optical integral field spectrograph of high throughput and *large field of view* ( $41'' \times 33''$ ). The instrument was commissioned at the WHT's Cassegrain focus in 1999.

The principal science driver was the 'SAURON survey', a project using 3D spectroscopy to study the formation and evolution of nearby early-type galaxies and bulges from their large-scale gaseous and stellar kinematics, and their line strength distributions (e.g. Fig 1). A recent novel application has been to use SAURON as a 'photon collector'. Measuring stellar dynamics of early-type galaxies out to large galactic radii is challenging due to their low surface brightness. However, by performing integral field spectroscopy with SAURON, and then coadding all  $\sim 1400$  spectra, one can attain a global spectrum of reasonable S/N ratio (see Fig 2).

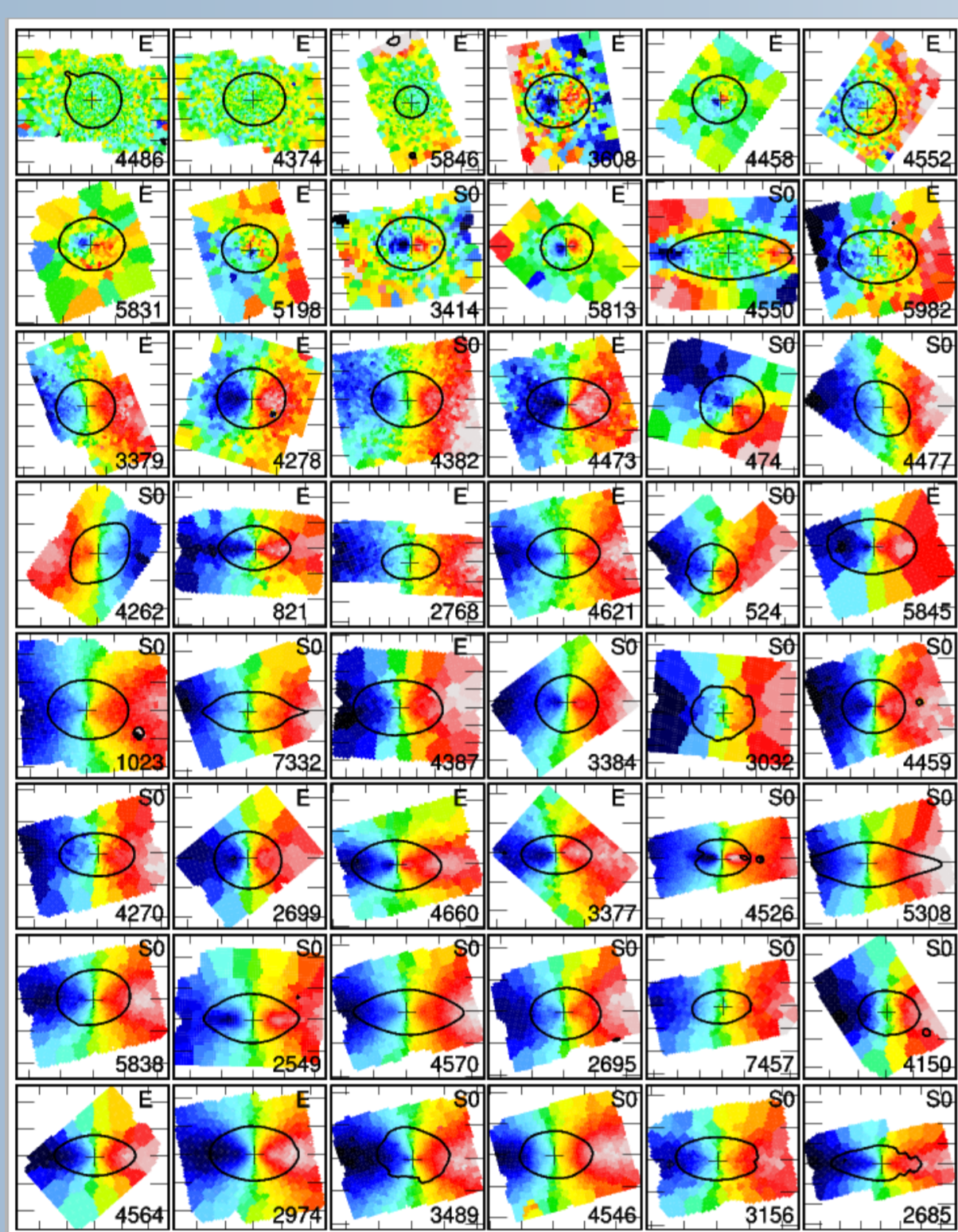

Fig 1: SAURON velocity fields for 48 elliptical and lenticular galaxies (Emsellem et al. 2007, MNRAS, 379, 401). These data form the basis for a new kinematical classification whereby early-type galaxies are defined as either slow (*top two rows*) or fast (*bottom six rows*) rotators. These two classes display distinct properties in terms of luminosity, photometric vs. kinematic axis alignment, velocity twists and orbital distribution.

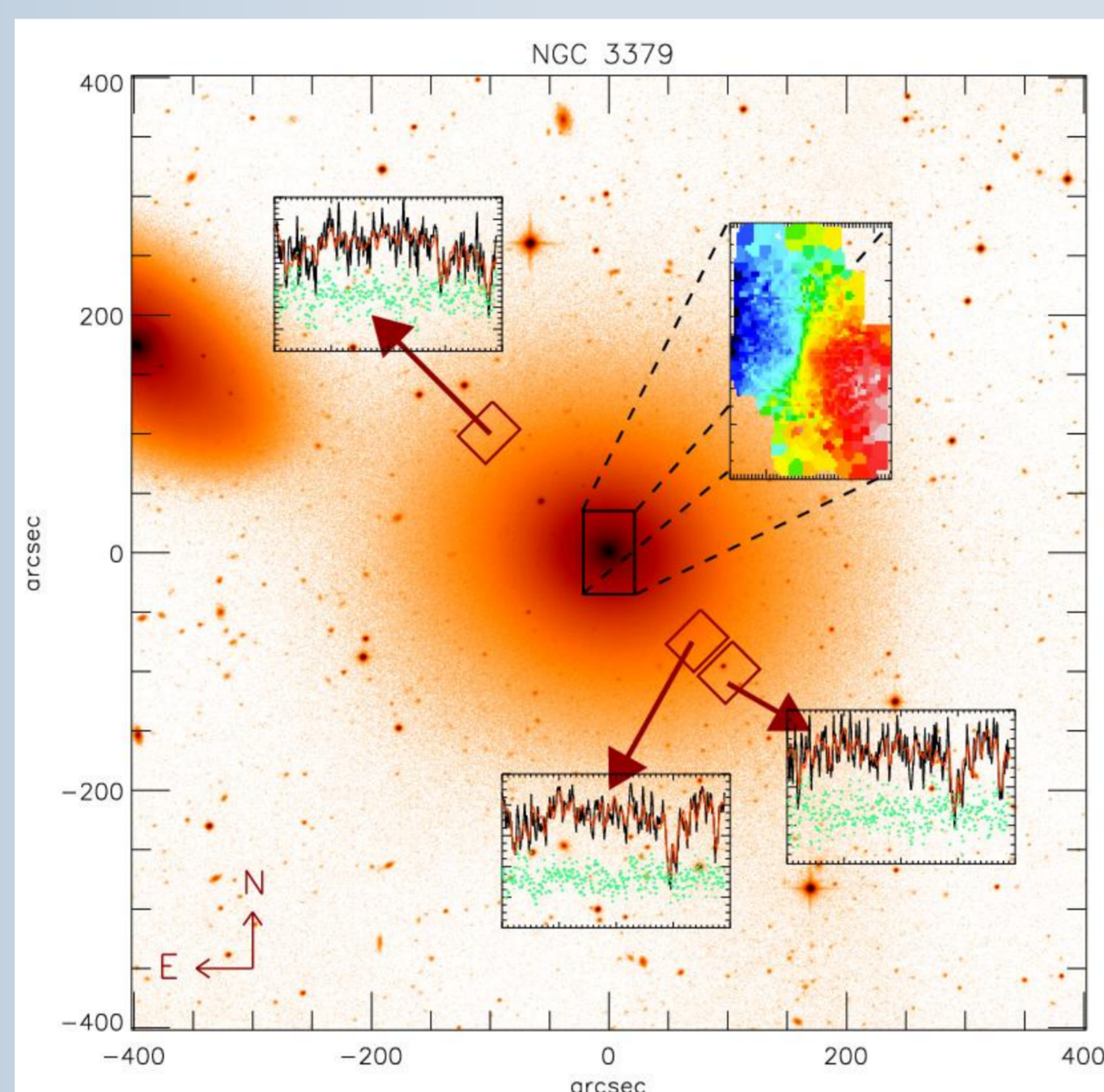

Fig 2: Studying the dark matter halo of NGC 3379. This V-band image of NGC 3379 shows three SAURON pointings that were centred at  $2.6\text{-}3.5 R_e$  (red rectangles) and their coadded spectra (black histograms). Also displayed is the central pointing (black rectangle) observed by the SAURON survey and its 2D velocity field. Weijmans et al. 2009 (MNRAS, submitted) used these data to construct dynamical models and found that approximately 35% of the total matter is dark out to  $4R_e$ .

## PNS

Planetary Nebulae (PNe) are excellent tracers of the kinematics of galaxies, particularly in their outer regions (up to  $4\text{-}5 R_e$ ). Measuring the radial velocities of extragalactic PNe is generally a two-stage process in which candidate PNe are first identified using [OIII] narrowband imaging and then follow-up spectroscopy is performed. The Planetary Nebula Spectrograph (PNS) is a unique instrument that *simultaneously* locates PNe and measures their radial velocities in a single observation using 'counter-dispersed imaging' (see Fig 4). It was designed and built by the PN.Spectrograph consortium and commissioned as a visitor instrument at the Cassegrain focus of the WHT in 2001.

The results from PNS challenge current theories of galaxy formation. Studies of the outer haloes of elliptical galaxies, particularly of intermediate luminosity, indicate a deficit of dark matter compared to the amount predicted by  $\Lambda$ CDM (see e.g. Douglas et al. 2007, ApJ, 664, 257; Romanowsky 2003, Science, 301, 1696).

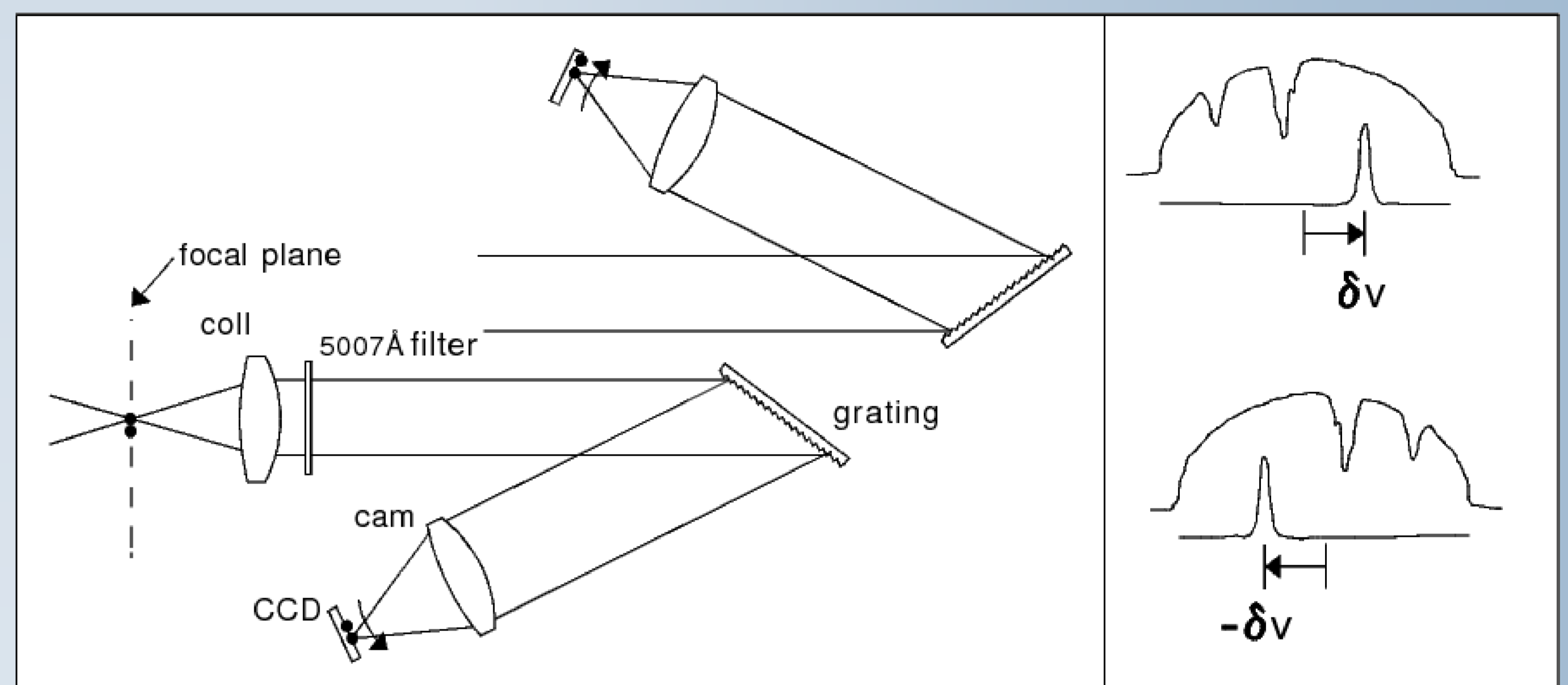

Fig 4: Counter-dispersed imaging. Consider observing both a star and a PN using a narrow bandpass filter centred around the [OIII] 5007 emission line and slitless spectroscopy. The star appears on the detector as a short spectrum, while the PN is detected as a point source due to its strong [OIII] emission. If the spectrograph is then rotated by 180 degrees, the dispersion direction is reversed while the field orientation remains the same. By locating the positions and separations of the PN in the two images one can determine its position on-sky and its radial velocity. PNS is unique because it consists of a pair of back to back identical spectrographs that permit *simultaneous* counter-dispersed imaging. (Figure reproduced from Douglas et al. 2002, PASP, 114, 1234).

## FASTCAM

FASTCAM is a 'lucky imager' built by the Instituto de Astrofísica de Canarias (IAC). It is based on an Andor 512x512 low-noise (L3) CCD, with a scale of 0.019 arcsec/pixel. The camera is usually mounted at the WHT's Nasmyth focus.

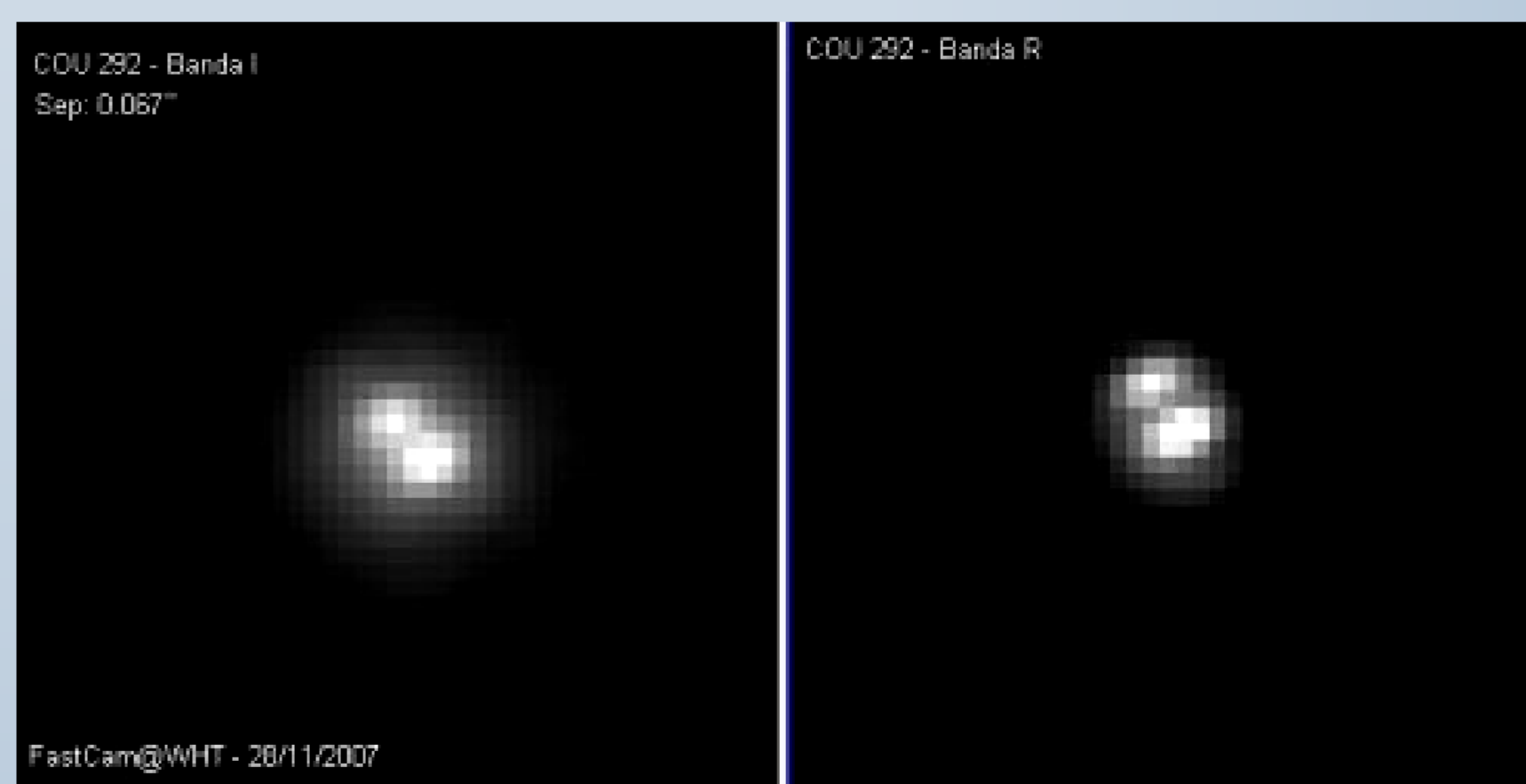

Fig 5: I- and R-band images of an 8th-mag binary star obtained during the commissioning of FASTCAM at the WHT. The separation of the components is 0.067 arcsec. The image was obtained by shifting and adding the best 5% of a series of 8000 30-msec images.

## ULTRACAM

ULTRACAM is an ultra-fast triple-beam CCD camera, designed for studying phenomena on timescales of msec to sec (see Fig 3a). It was built by a collaboration between the Universities of Sheffield and Southampton.

The instrument was recently used to verify a long-standing prediction of binary star evolution theory: the existence of 'dead' cataclysmic variables, in which the white dwarf is accreting from a substellar donor star. By observing eclipses of CV SDSS1035 at high time resolution (see Fig 3b), ULTRACAM made it possible to measure the mass of the donor star. At  $0.052 \pm 0.002$  solar masses, the donor was confirmed to be a brown-dwarf, making this the first observation of a dead cataclysmic variable (Littlefair et al. 2006, Science, 314, 1578).

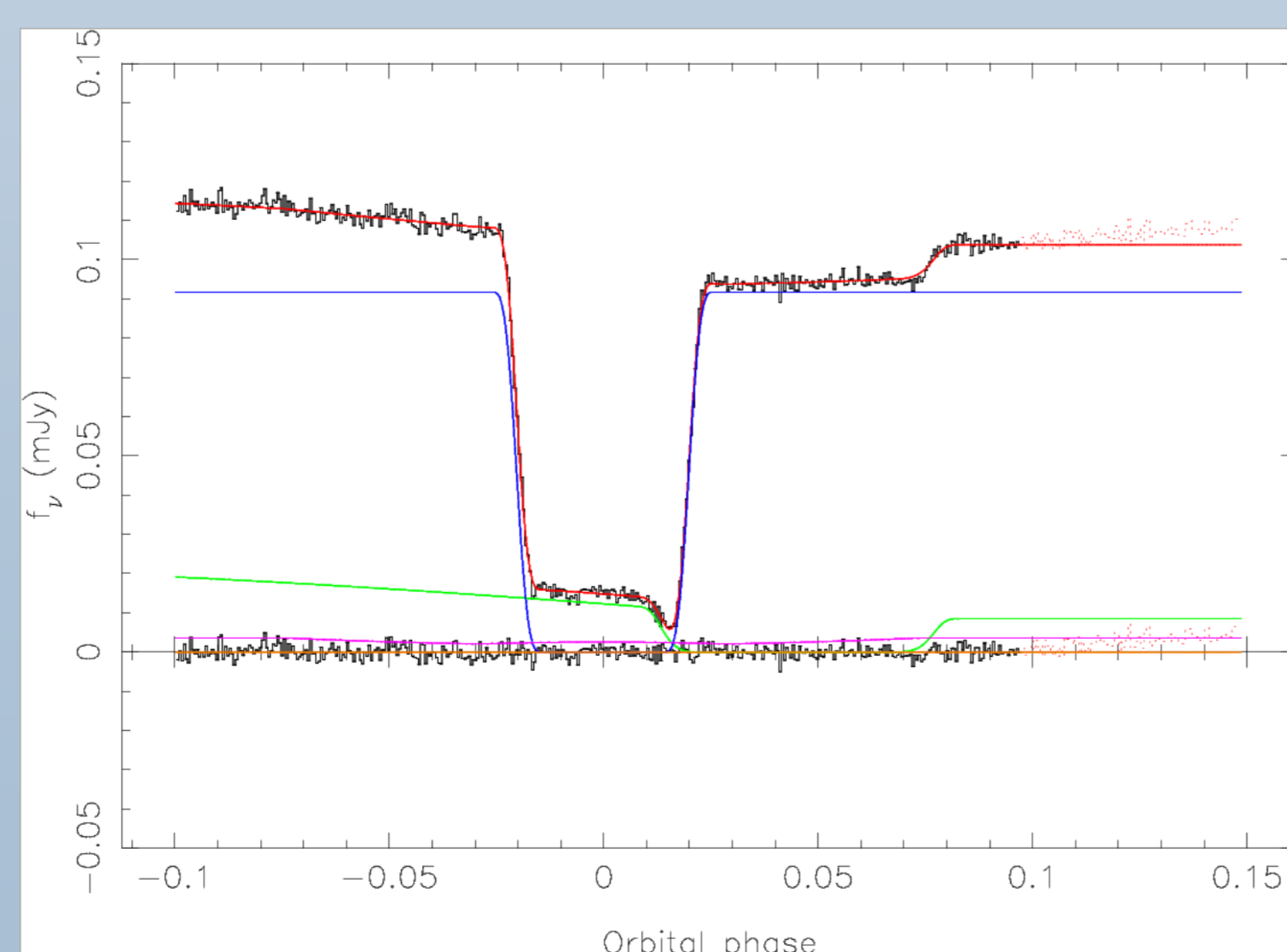
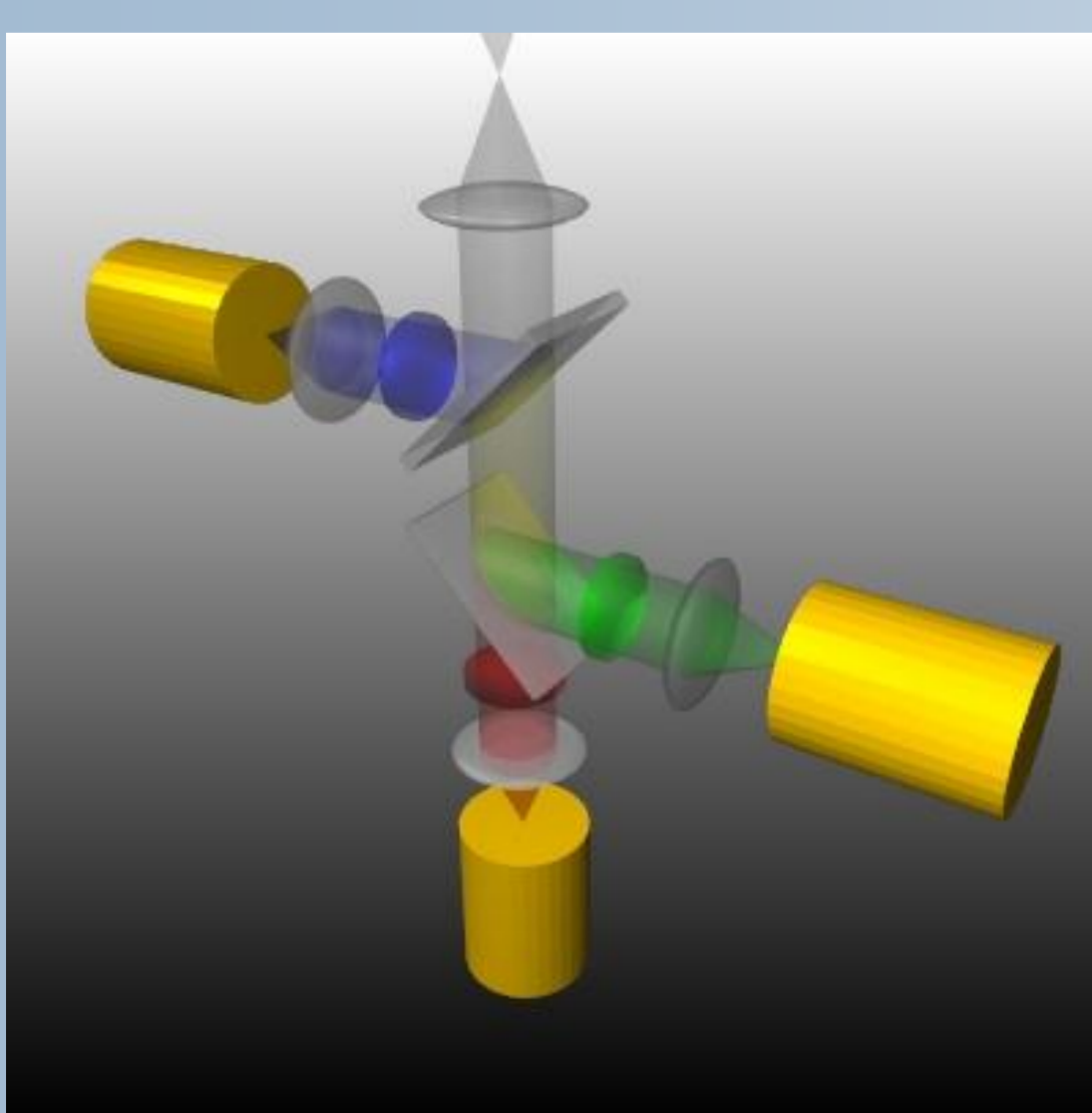

Fig 3: (a) Dichroic beamsplitters in ULTRACAM direct the blue, green and red light to three separate cameras. (b) Eclipse of CV SDSS1035. The figure shows the ULTRACAM lightcurve and residuals (black curves), the eclipse model (red), the white dwarf component of the model (blue), the bright spot component (green) and the accretion disc (purple).

## Bringing your Instrument to the WHT

- The WHT is a world class 4.2m telescope, located at an excellent observing site within easy reach of mainland Europe. Visiting instrument teams from *any* country are eligible to apply for observing time.
- Visiting instruments are usually mounted either at Cassegrain or on an optical bench at the Nasmyth focus. ING CCDs and the associated data acquisition system may be used, along with other ING facilities (e.g. lamp calibration units, filters, etc).
- ING staff have considerable expertise in interfacing visitor instruments to the telescope and its subsystems. Visiting instrument teams may call upon this expertise at all stages from instrument design to observing.

ING encourages instrument-building teams to bring their instruments to the WHT and strives to make this process straightforward. For further information contact Chris Benn ([crb@ing.iac.es](mailto:crb@ing.iac.es)) or see <http://www.ing.iac.es/Astronomy/observing/NewVisitorInstruments.html>.