

CHECK DIMENSION OF CASE OPENING
MANUFACTURE DOOR TO SUIT

NOTE

EXTERNAL FINISH - PAINT TO SUIT CASE BROLAC BS20 D45/JS
MARITIME BLUE OR SIMILAR (PRIMER TO SUIT)

INTERNAL FINISH - PAINT MATT BLACK

Issue	Mod.No	Date	Drawn by	Issue	Mod.No	Date	Drawn by
						SEPT. 87	AJW

Tolerance (Unless otherwise stated)	X +/-	X.X +/-	0.5	X.XX +/-	0.1
-------------------------------------	-------	---------	-----	----------	-----

Material	AL ALLOY
Finish	SEE NOTE

I OFF	
Dwg.No.	No. Req.
Used on	

Dimns. in m.m.	Scale 1:1
ROYAL GREENWICH OBSERVATORY	
HERSTMONGEUX CASTLE	
HAILSHAM, SUSSEX	

THIRD ANGLE PROJECTION	
4.2m A & G UNIT	
FILTER SLIDE ACCESS DOOR	

GA No.	W/FX/260
Drawing No.	W/FX/264

Drawing No.
W/FX/271

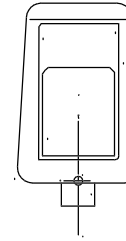
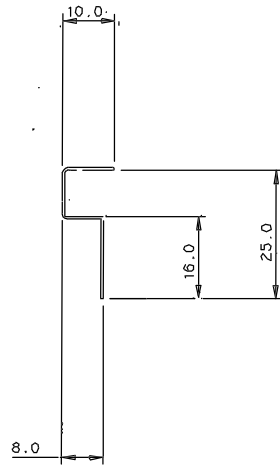
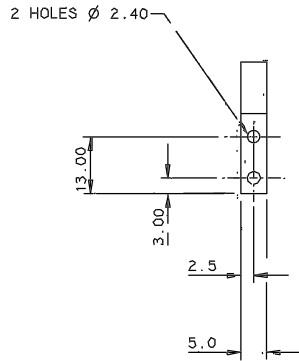

BEND END TO SUIT PROFILE
OF DOOR - NOMINAL ANGLE 60°

DRILL \varnothing 3.50 HOLE THRU
POSITION TO SUIT LOCKING PIN

TITLE		DISC REF.	
271	SWITCH FLAG		
MATERIAL	SCALE	TOLERANCES \pm	
BRASS	2:1	X	0.5
FINISH	No. REQD. PER UNIT	X.X	
BLK. NICKEL PL.	1 OFF	X.XX	0.1
G.A. No.	DRAWING No.		
W/FX/260	RG0 W/FX/271		

TITLE		DISC REF.	
272	LEVER LATCH		
MATERIAL	SCALE	TOLERANCES \pm	
DZUS 2102	1:1	X	
FINISH	No. REQD. PER UNIT	X.X	
	1 OFF	X.XX	
G.A. No.	DRAWING No.		
W/FX/260	RG0 W/FX/272		

Issue	Mod.No	Date	Drawn by	Issue	Mod.No	Date	Drawn by	Tolerance (unless otherwise stated)	Material	Finish	Dimns. in m.m.	Scale	THIRD ANGLE PROJECTION	GA No.
								X +/-					ROYAL GREENWICH OBSERVATORY, HERSTMONCEUX CASTLE HAILSHAM SUSSEX	Drawing No. W/FX/271
								X.X +/-					THE 4.2m A & G UNIT - FILTER ACCESS DOOR DETAILS - LATCHING MECHANISM	
								X.XX +/-						

Drawing No.
W/FX/265-70

REMOVE ALL SHARP EDGES

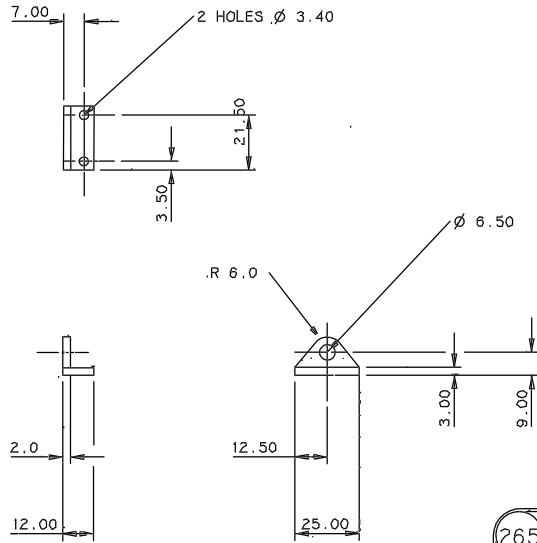

TITLE		DISC REF.	
265	CYLINDER BRACKET		
MATERIAL	SCALE	TOLERANCES ±	
AL. ALLOY	1:1	X	0.5
FINISH	No. REQD. PER UNIT	X.X	0.1
BLK. ANODISE	1 OFF	X.XX	0.1
G.A. No.	DRAWING No.		
W/FX/260	RG0 W/FX/265		

REMOVE ALL SHARP EDGES

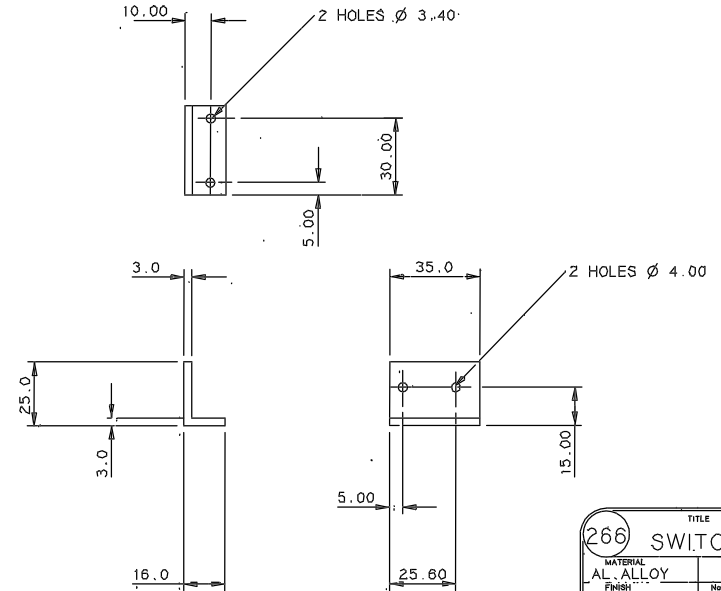

TITLE		DISC REF.	
266	SWITCH BRACKET		
MATERIAL	SCALE	TOLERANCES ±	
AL. ALLOY	1:1	X	0.5
FINISH	No. REQD. PER UNIT	X.X	0.1
BLK. ANODISE	1 OFF	X.XX	0.1
G.A. No.	DRAWING No.		
W/FX/260	RG0 W/FX/266		

REMOVE ALL SHARP EDGES

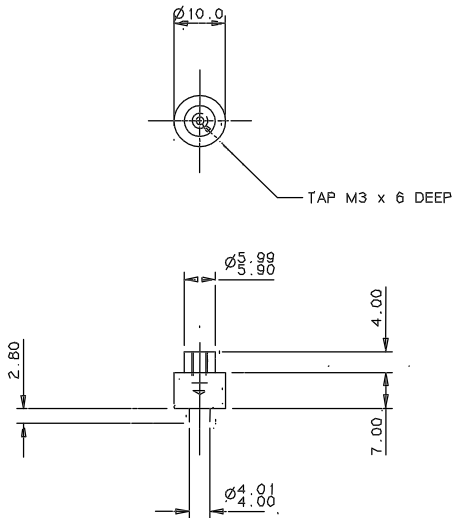

TITLE		DISC REF.	
267	PIVOT		
MATERIAL	SCALE	TOLERANCES ±	
ST. STL.	2:1	X	0.5
FINISH	No. REQD. PER UNIT	X.X	0.1
CLEAN	1 OFF	X.XX	0.1
G.A. No.	DRAWING No.		
W/FX/280	RG0 W/FX/267		

REMOVE ALL SHARP EDGES.

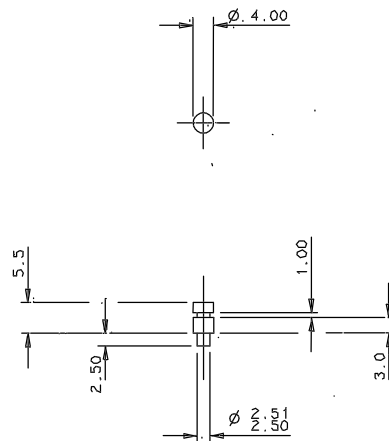

TITLE		DISC REF.	
268	SPRING POST		
MATERIAL	SCALE	TOLERANCES ±	
ST. STL.	2:1	X	0.5
FINISH	No. REQD. PER UNIT	X.X	0.1
CLEAN	2 OFF	X.XX	0.1
G.A. No.	DRAWING No.		
W/FX/260	RG0 W/FX/268		

REMOVE ALL SHARP EDGES

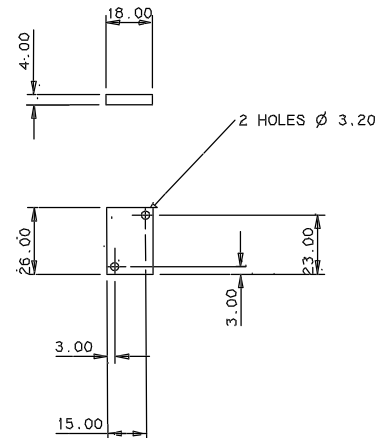

TITLE		DISC REF.	
269	SPACER		
MATERIAL	SCALE	TOLERANCES ±	
AL. ALLOY	1:1	X	0.5
FINISH	No. REQD. PER UNIT	X.X	0.1
BLK. ANODISE	1 OFF	X.XX	0.1
G.A. No.	DRAWING No.		
W/FX/260	RG0 W/FX/269		

REMOVE ALL SHARP EDGES

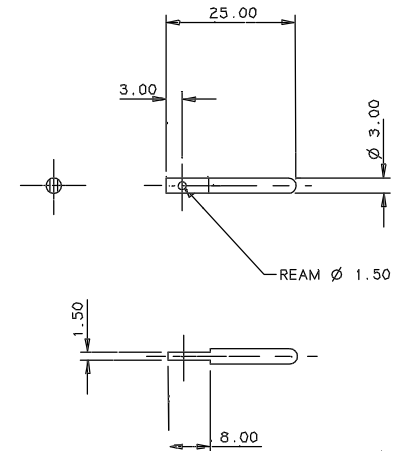

TITLE		DISC REF.	
270	LOCKING PIN		
MATERIAL	SCALE	TOLERANCES ±	
ST. STL.	2:1	X	0.5
FINISH	No. REQD. PER UNIT	X.X	0.1
CLEAN	1 OFF	X.XX	0.1
G.A. No.	DRAWING No.		
W/FX/260	RG0 W/FX/270		

Issue	Mod. No.	Date	Drawn by	Issue	Mod. No.	Date	Drawn by
				1		OCT. 87	AJW

Material		Dimns. in mm. - Scale	
Finish		Org. No.	No. Req.
		Used on	

ROYAL GREENWICH OBSERVATORY
HERSTMONCEUX CASTLE
HAILSHAM SUSSEX

THIRD ANGLE PROJECTION
Title 4.2m A & G UNIT - FILTER ACCESS DOOR
DETAILS - LATCHING MECHANISM

GA No.
Drawing No.
W/FX/265-70

DRAWING NUMBER	No. OF SHEETS	GA ITEM No.	DRAWING TITLE OR COMPONENT NAME	No. OFF	MATERIAL STOCK OR ORDER No. AND DATE	REMARKS	ISSUE DATE	ISSUED TO	FINISH DATE
W/ FX / 260	1		ASSEMBLY						
W/ FX / 261		261	BASEPLATE	1	AL, ALLOY				
/ / 262	1	262	BEARING BLOCK	1	BRASS				
/ / 263		263	LEVER	1	"				
W/ FX / 264	1	264	FILTER SLIDE ACCESS DOOR	1	AL, ALLOY				
W/ FX / 265		265	CYLINDER BRACKET	1	"				
/ / 266		266	SWITCH BRACKET	1	"				
/ / 267	1	267	PIVOT	1	ST, STEEL				
/ / 268		268	SPRING POST	2	"				
/ / 269		269	SPACER	1	AL, ALLOY				
/ / 270		270	LOCKING PIN	1	ST, STEEL				
W/ FX / 271	1	271	SWITCH FLAG	1	BRASS				
/ / 272		272	MODS. TO LEVER LATCH	1	DZUS 2102				
/ /		273							
/ /		274							
/ /		275							
/ /		276							
/ /		277							
/ /		278							
/ /		279							
/ /		280	CYLINDER S/A 12.5 STROKE	1	KUHNKE 38-150-012				
/ /		281	3/2 SOLENOID VALVE	1	KUHNKE 64-001-12VDC				
/ /		282	PLUG IN SOCKET	1	KUHNKE 64-230				
/ /		283	RESTRICTOR	1	KUHNKE 47-220				
/ /		284	TUBE COUPLING	2	KUHNKE 50-007				
/ /		285	COUPLING MASTER	1	KUHNKE 50-061-01				
/ /		286	SOCKET	1	KUHNKE 50-065				
/ /		287	HINGE	2	SOUTHCO E6-10-301-20				
/ /		288	PROXIMITY SWITCH	1	HETTICH SO35 A/R				
/ /		289	LIMIT SWITCH	1	RS 330-678				
/ /		290	SPRING	1	TO SUIT				
/ /									
/ /									
/ /									
/ /									
/ /									
/ /									
JOB TITLE 4.2m A & G UNIT - FILTER ACCESS DOOR						ASS'Y DRG No. W/FX/260	SHEET No. 1 OF 1	DRAWN BY AJW	
ROYAL GREENWICH OBSERVATORY, HERSTMONCEUX CASTLE, HAILSHAM, EAST SUSSEX.								DATE OCT. 87	

Drawing No.
W/FX/261-3

REMOVE ALL SHARP EDGES

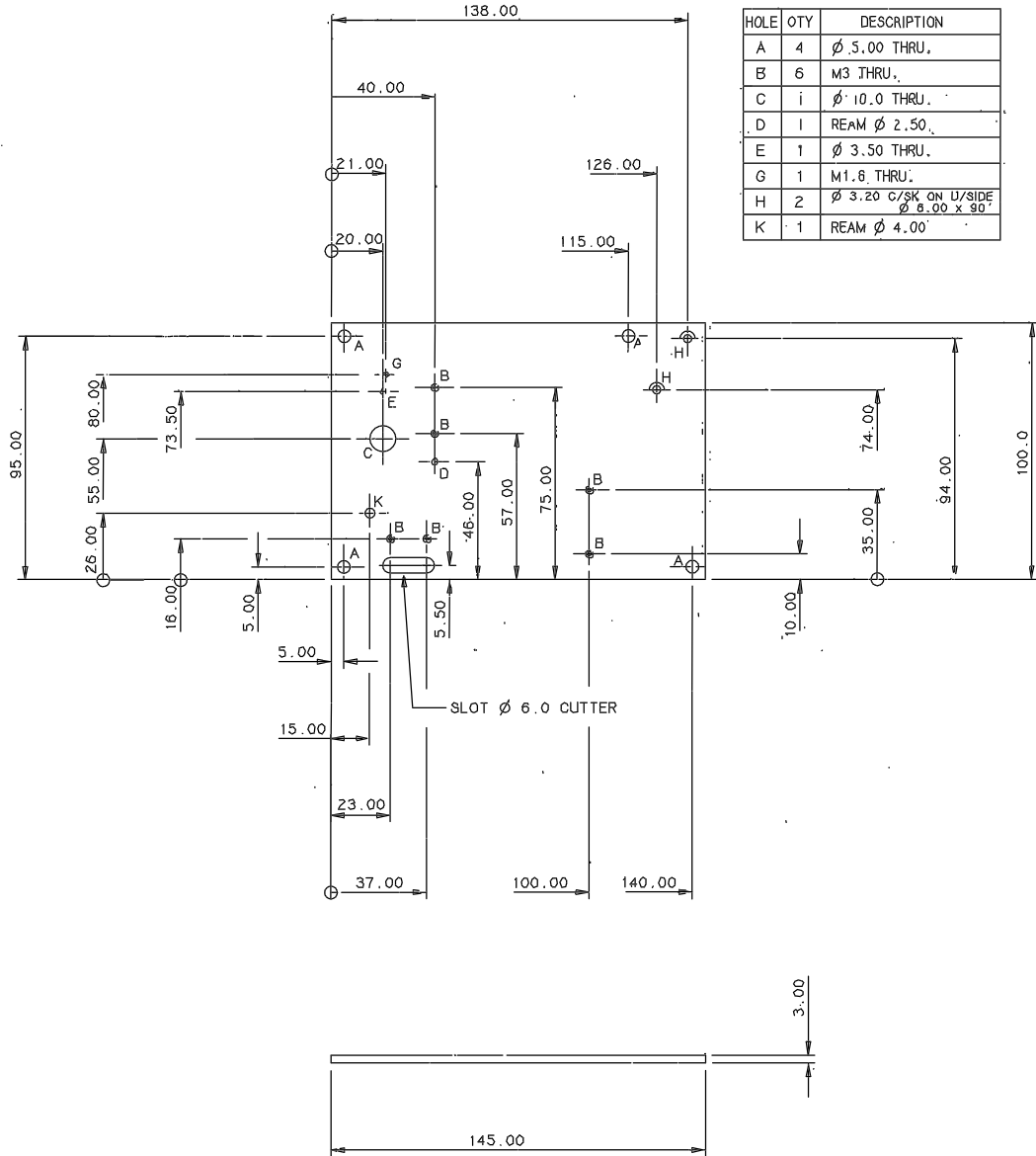

HOLE	QTY	DESCRIPTION
A	4	∅ 5.00 THRU.
B	6	M3 THRU.
C	1	∅ 10.0 THRU.
D	1	REAM ∅ 2.50
E	1	∅ 3.50 THRU.
G	1	M1.6 THRU.
H	2	∅ 3.20 C/SK ON U/SIDE ∅ 6.00 x 90°
K	1	REAM ∅ 4.00

TITLE		DISC. REF.	
26.1 BASEPLATE			
MATERIAL	SCALE	TOLERANCES ±	
AL. ALLOY	1:1	X	0.5
FINISH	No. REQD. PER UNIT	X.X	0.1
BLK. ANODISE	1 OFF	X.XX	0.1
G.A. No.	DRAWING No.		
W/FX/260	RGD W/FX/261		

REMOVE ALL SHARP EDGES

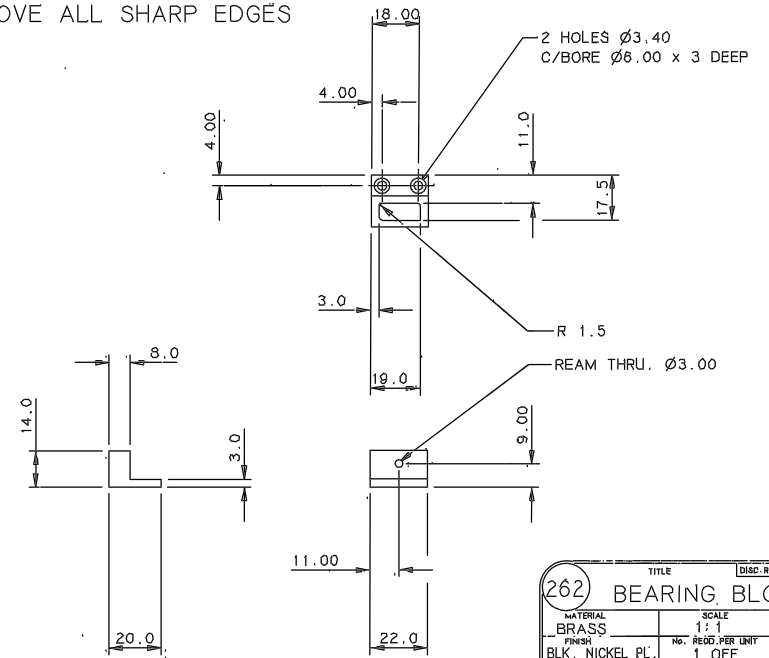

TITLE		DISC. REF.	
26.2 BEARING BLOCK			
MATERIAL	SCALE	TOLERANCES ±	
BRASS	1:1	X	0.5
FINISH	No. REQD. PER UNIT	X.X	0.1
BLK. NICKEL PL.	1 OFF	X.XX	0.1
G.A. No.	DRAWING No.		
W/FX/260	RGD W/FX/262		

REMOVE ALL SHARP EDGES

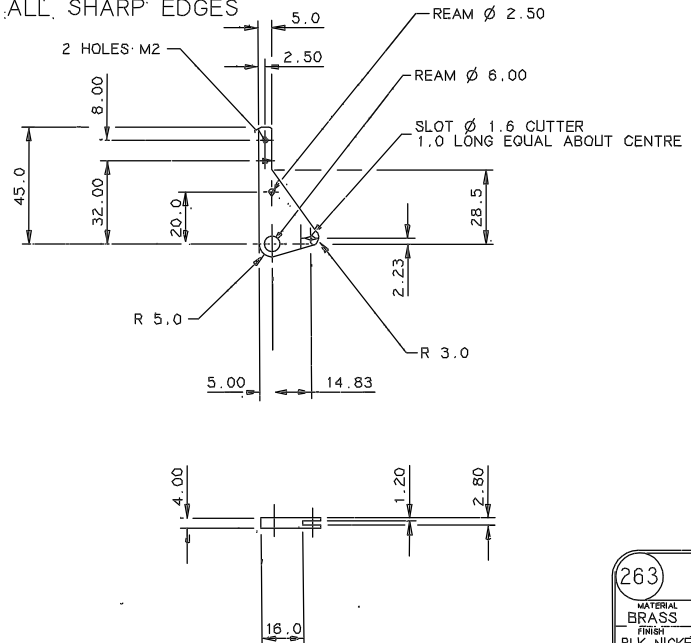

TITLE		DISC. REF.	
26.3 LEVER			
MATERIAL	SCALE	TOLERANCES ±	
BRASS	1:1	X	0.5
FINISH	No. REQD. PER UNIT	X.X	0.1
BLK. NICKEL PL.	1 OFF	X.XX	0.1
G.A. No.	DRAWING No.		
W/FX/260	RGD W/FX/263		

Issue	Mod.No	Date	Drwn by	Issue	Mod.No	Date	Drawn by	Tolerance (Unless otherwise stated)	Material	Dirms. In m.m.	Scale	THIRD ANGLE PROJECTION	GA No.
			1			SEPT. 87	AJW	X +/-	ROYAL GREENWICH OBSERVATORY			4.2m A & G UNIT - FILTER ACCESS DOOR	Drawing No.
								X.X +/-	HERSTMONCEUX CASTLE			DETAILS - LATCHING MECHANISM	W/FX/261-3
								X.XX +/-	HAILSHAM SUSSEX				

Drawing No.
W/FX/260

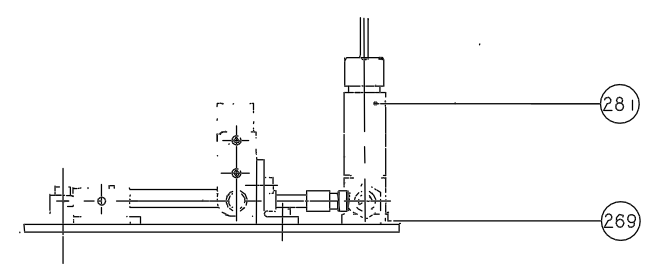
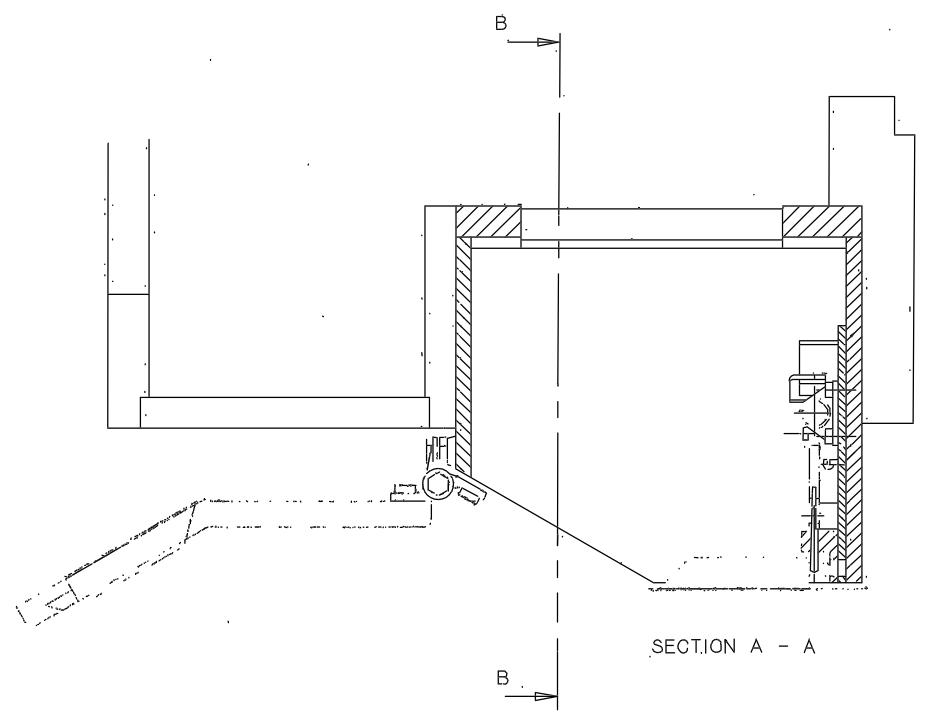
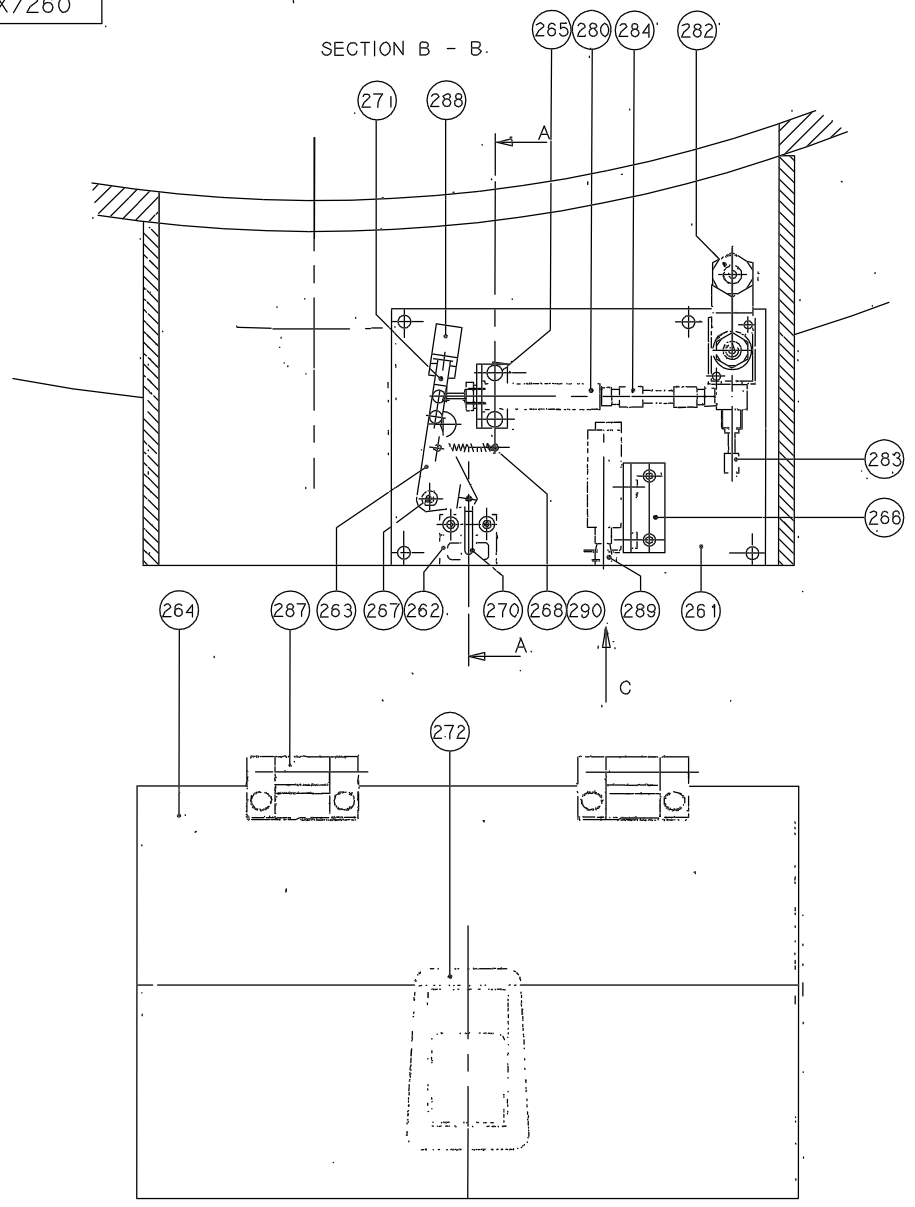

VIEW ON, ARROW C
LATCHING ASS'Y ONLY

								Tolerance (unless otherwise stated)		Material		Dimns. in m.m.		Scale 1:1		THIRD ANGLE PROJECTION		GA No.	
								X +/-		Finish		1 OFF		ROYAL GREENWICH OBSERVATORY		Title		Drawing No.	
								X.X +/-		.Drg. No.		HERSTMENCEUX CASTLE		4.2m A. & G UNIT		W/FX/260			
								X.XX +/-		Used on		HAILSHAM SUSSEX		FILTER ACCESS DOOR					
Issue	Mod. No.	Date	Drawn by	Issue	Mod. No.	Date	Drawn by												
				1		OCT. 87	AJW												