

Prototype Version

Auxillary card

Utility card (modifications)

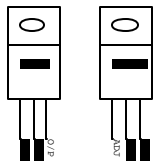
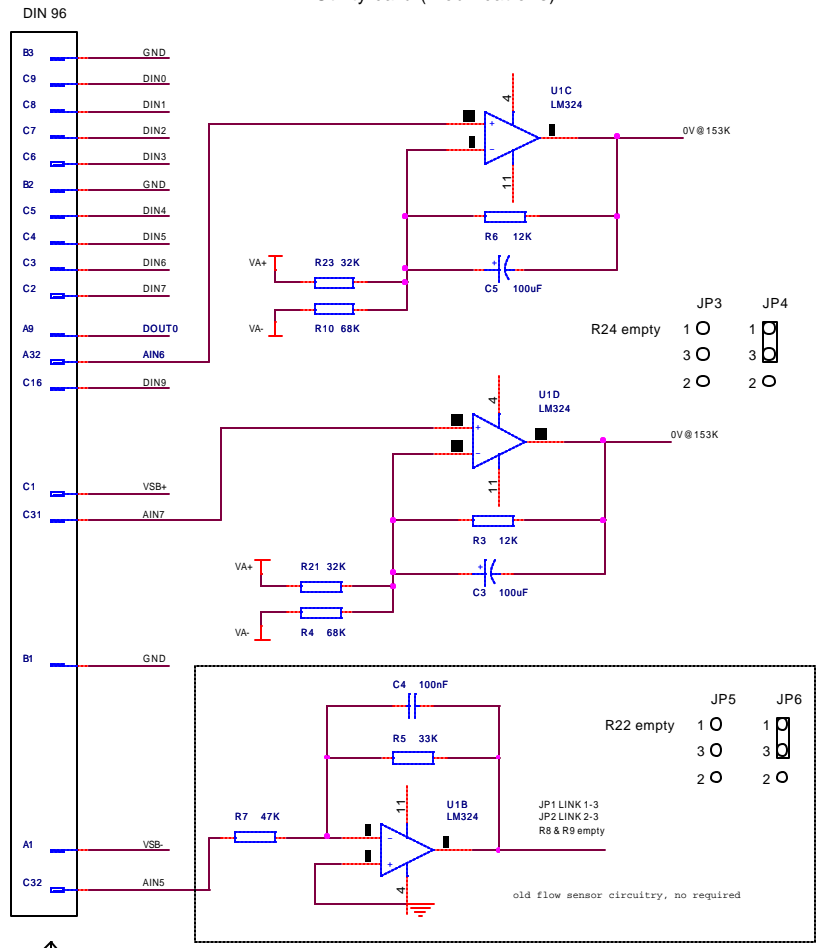
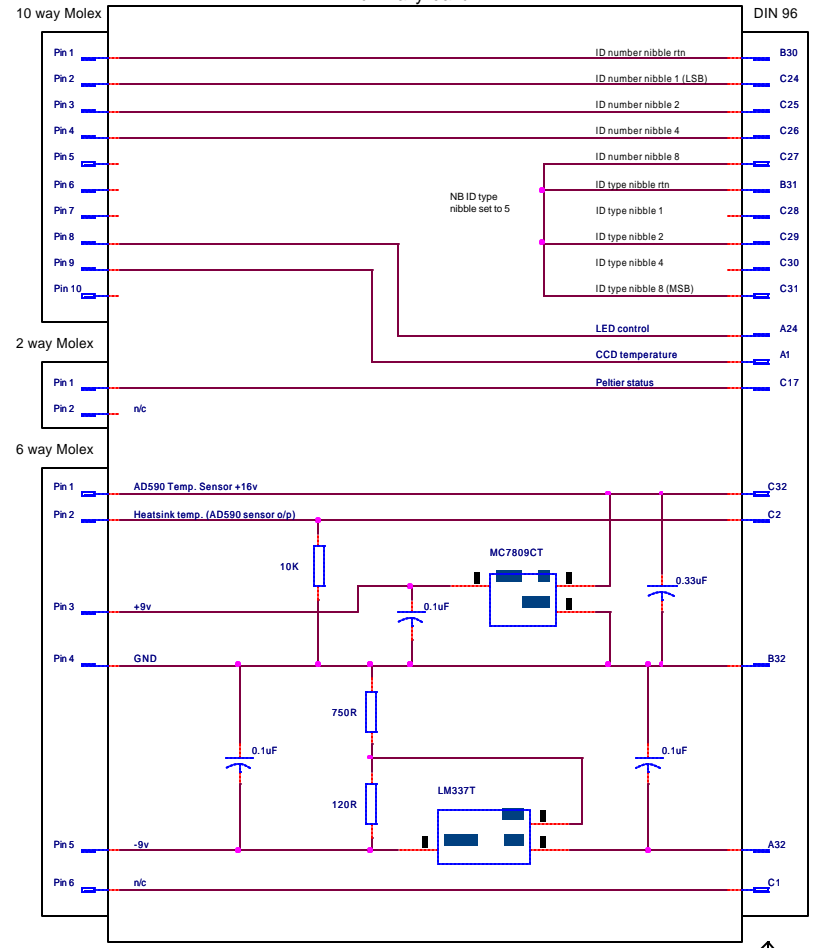
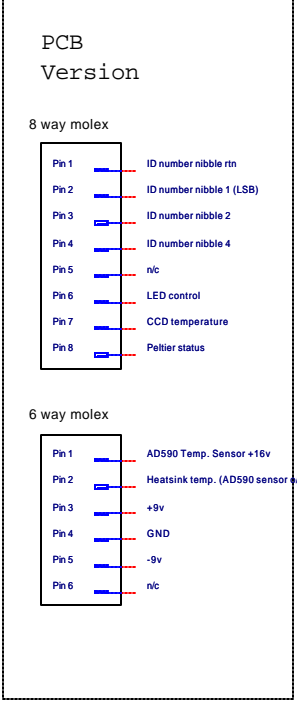

These numbers refer to Utility card 96 way connector numbering which is non standard.

These numbers refer to auxillary card 96 way connector numbering which is standard

Title			
SDSU Autoguide Auxillary board			
Size B	Document Number		Rev
	SDSUAuto05		
Date:	Friday, January 21, 2005	Sheet	1 of 1